

Product Data Sheet

LED HIGH-BAY

SPACE - 100W

CODE: **3022870**

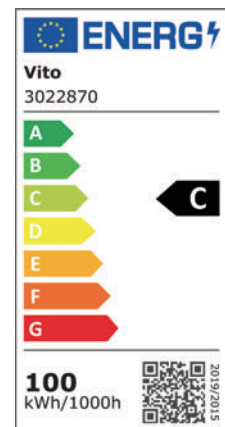

Area of application

- Warehouses
- Logistics halls
- Industry
- Indoor and outdoor
- High ceiling (e.g. in shopping malls, airports, commercial buildings)

Product Advantages

Direct replacement for conventional 400W HQL High Bay luminaires

Exclusive VITO design

Lumileds brand LED chip inside

Energy savings of up to **80%** compared to conventional high bay luminaires

Optimized weight and size due to compact design

Mounting hook included

Available certificates: CE, EMC, LVD

VITO EUROPE
102 Iztochna Tangenta str. 4th Floor
P.C. 1528, Sofia/Bulgaria
Phone: +359 2 4341575
E-mail: info@vitoeurope.com

www.vitolighting.com

Product Data Sheet

LED HIGH-BAY

SPACE - 100W

CODE: **3022870**

Product Features

Power: 100W

Luminaire efficacy: 150 lm/W

Luminous flux: 15000lm

Colour temperature: 5000K

Beam angle: 90°

IP Class: IP65

IK Class: Class I

Lifetime: (L70/B50): up to 50000h

Dimmable: No

Voltage: 100-277V

Hyper Voltage Protection: 10KV

Body color: Black

Body Material: Aluminum+PC

Lens material: Polycarbonate

Ambient operating temperature: -10+50 °C

Guarantee: 5 years

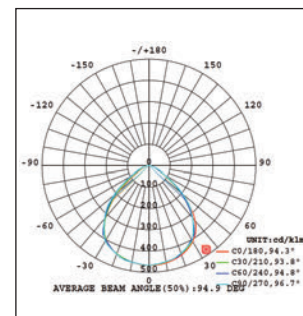
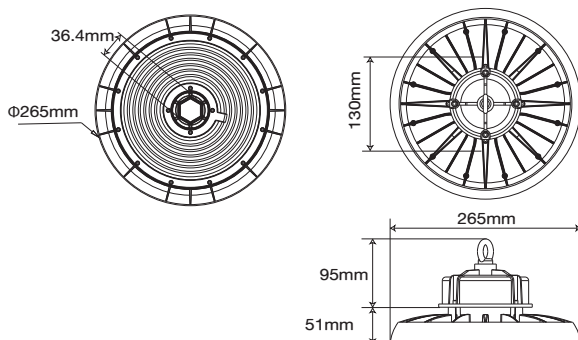

Packing Informations

Dimensions: 280x280x140mm

Volume: 0.011m³

Gross Weight: 3kg

Pieces/box: 1